



## UNI-LOCK SYSTEM



THE UNI-LOCK SYSTEM is designed to fix a wire suspension to a variety of different base materials including timber, concrete, plasterboard or steel. It incorporates a 90 degree bracket which is factory-swaged to the wire suspension.

A suitable fixing for the intended base material is then used to fix the suspension to the ceiling.

### AVAILABILITY

Uni-Lock is available with the following safe working loads (SWL):

- **G** system - 10 kg SWL
- **S** system - 50 kg SWL
- **Y** system – 90 kg SWL

**Note:** G-system should not be used for HVAC.

Uni-Lock is available for drop lengths of 1 m to 10 m. Loads indicated are per individual wire when coupled with the appropriate Zip-Clip locking device.

**P** system and **N** system Uni-Lock suspensions are available on request.

### FIXINGS

Fixing Type	Compatible Base Material
Timber screw	Wood
Concrete screw	Concrete or concrete over metal deck
Plug and screw	Concrete
Toggle fixing	Plaster board
Gas nail/pin	Steel or concrete

- Ensure all fixings are suitable for the base material.
- Ensure all fixings are suitable to support the intended load.
- Ensure all fixings match SWL of the wire suspension.

#### Suitable Fixings:

- DRIVA plug + screw.
- Traditional plug + screw.
- Tek screws/ sheet metal screws.
- Woods screws.
- TAPCON concrete screws or equivalent.
- SPIT/HILTI gas nails.
- FISCHER FNA 11 concrete fixing with pan head.

### INSTALLATION

- The first step for the installation process is to attach the wire support by anchoring the 90° bracket.
- The second step for installation process is to install the Zip-Clip locking device and connect to the intended application.

#### Stage 1: Attaching the 90° bracket to the wooden base material

- 1 Drill a pilot hole into base material suitable for the chosen fixing ensuring correct depth and diameter.
- 2 Couple bracket with a suitable wood screw (or other fixing) and penny washer.
- 3 Offer bracket and screw up to pre-drilled hole and tighten screw to clamp bracket in place.

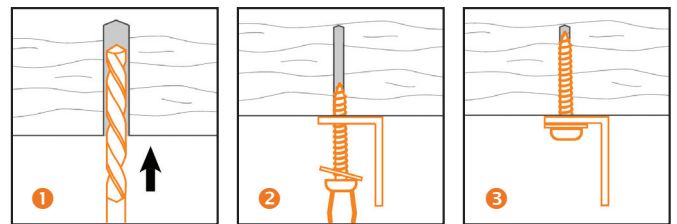

#### Stage 2: Installing the Zip-Clip locking device

Once the 90° bracket has been installed, a Zip-Clip locking device can be used to attach the wire to the service.

- 1 Pass the wire rope through the Zip-Clip device in the direction of the arrow.
- 2 Pass the wire rope through or around your required fixture/application and back through the Zip-Clip leaving 15 cm of wire protruding (exit tail).
- 3 Confirm engagement of the Zip-Clip on the wire by pushing the pin in the **opposite** direction to the arrows indicated.

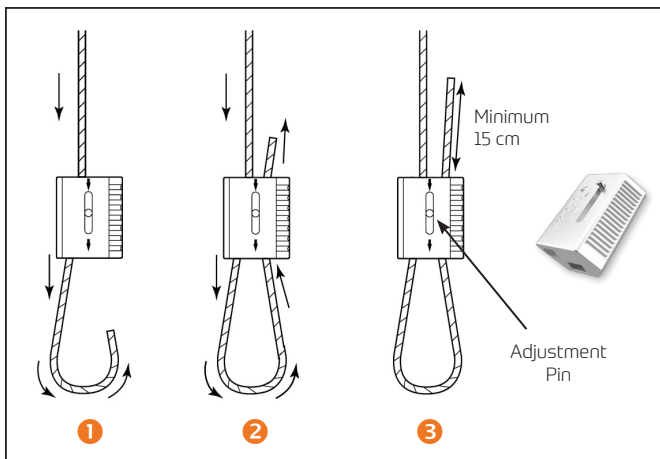

## ADJUSTMENT OF THE LOCKING DEVICE

**Please note:** Before any adjustments can be made it is necessary to take all weight off the Zip-Clip device. It will not be possible to make adjustment if this is not done.

### To shorten the suspension:

1. Push the Zip-Clip device further up the live (load) wire – This will make the loop bigger.
2. Pull on the dead wire (exit tail) to make the loop smaller – This will shorten the suspension.
3. Trim the dead wire tail to minimum 15 cm or coil the wire neatly to allow for future adjustment.

### To lengthen the suspension:

1. Select the channel that holds the dead wire.
2. Make sure there is enough spare dead wire to allow for adjustment whilst maintaining an exit tail.
3. Push the adjustment pin in the direction of the arrow. This will release the dead wire (exit tail).
4. Allow the dead wire to feed back through the Zip-Clip. This will make the loop bigger.
5. Now select the channel that holds the live wire (load).
6. Push the adjustment pin in the direction of the arrow. This will release the live wire.
7. Allow the Zip-Clip to travel down the live wire. This will make the loop smaller.

## DIMENSIONS OF THE 90° BRACKET

System	Bracket	Gauge (mm)	a (mm)	b (mm)	c (mm)	Hole 1 (mm)	Hole 2 (mm)
G	HCB1	1.0	26.0	26.0	22.0	4.5	7.0
S	HCB2	2.0	40.0	30.0	19.0	6.5	6.5
Y	HCB3	2.0	40.0	30.0	19.0	6.5	11.0

## MATERIALS

### The 90° Brackets:

Manufactured from galvanised steel. HCB1 has bright zinc plate finish, HCB2 and HCB3 have Delta-Tone 9000 (480 hours) finish.

### Zip-Clip Devices:

Zamak zinc alloy main body with internal stainless steel spring and sintered steel locking wedge(s).

### Wire Rope:

Galvanised mild steel electro-galvanised wire rope, 1960 N/mm<sup>2</sup> grade, 7×7 IWRC construction, manufactured to BS EN 12385.

### Swages (also known as Ferrules):

Manufactured from seamless aluminium tube, finished in-house utilising a 25T cylindrical press die with cutting edge. Compliant with BS EN 13411-3 and suitable for wire ropes manufactured to BS EN 12385.

- 18th Edition Amendment 2 : 2022 compliant.

## MANUFACTURERS RECOMMENDATIONS

The Zip-Clip Uni-Lock system is designed to support **STATIC loads only**. Dynamic and shock loads must be avoided and can greatly increase the overall weight of the product being suspended and therefore compromise the safe working load of the suspension. To ensure integrity and safety of the system only Zip-Clip wire should be used.

- Do not exceed the safe working load (SWL) of the product.
- Do not use locking devices with a coated wire.
- Do not paint or apply any other coating.
- Do not lubricate.
- Do not use for lifting applications.
- Remove any frayed cable prior to inserting into the locking devices.
- Do not shock load.
- Do not use for dynamic loads/installations.
- Do not overload.
- Do not mix Zip-Clip systems with other wire suspension manufacturers products.
- Do not use in corrosive environments, e.g. chlorinated environments – For specialist applications, such as corrosive environments, please contact Zip-Clip Technical Department.

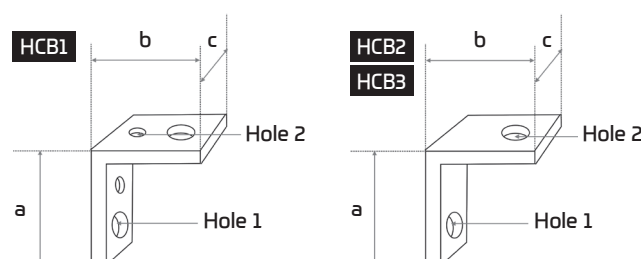

For further information on Zip-Clip suspension solutions, for technical or sales enquiries, contact us on Tel: +44 (0)1686 623366 • Email [info@zip-clip.com](mailto:info@zip-clip.com)