



ARCHITECTURAL SUSPENSION SYSTEMS



Y-HANGER ARCHITECTURAL SUPPORT

18th Edition Amendment 2:2022 compliant.

Architectural support, manufactured from bright nickel-plated brass and designed for lightweight applications. Used to create an inverted Y-shape wire support, ideal for fixtures with wide fixing centres such as light fittings.

AVAILABILITY

Product code: **AC3WAY**

Safe working load (SWL): 15 kg.

The range consists of a predetermined length of wire from 1 to 3 metres. Spanning wire with toggle all at 300 mm long.

Each wire support comes complete with the desired fixing end, length of wire required, architectural Y-hanger, and spanning wire with toggle legs.

FEATURES AND BENEFITS

- Allows for one single suspension point from the ceiling.
- Fully lockable plunger for safety and security.
- Side exit for main vertical wire support which allows for height adjustment at service level.
- Can be supplied with a variety of ceiling fixings.
- Available in kit format – lengths from 1-3 metres.
- Lockable grub screw to secure/adjust toggle legs (requires 3 mm Allen key/bit).

DIMENSIONS

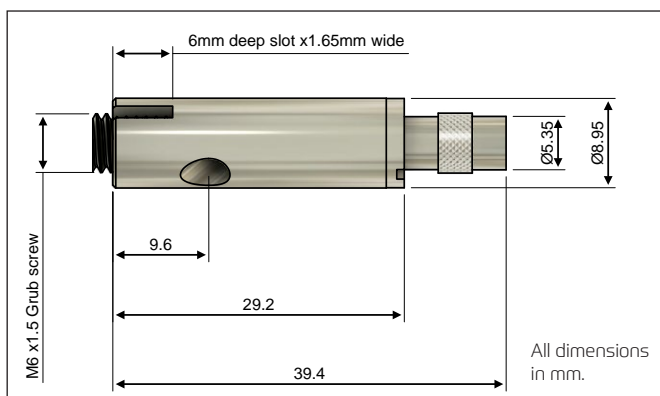

AVAILABLE END FIXING OPTIONS

Loop end	M6 concrete fixing	Architectural base plate

MATERIALS

3-way architectural support:

Bright nickel-plated brass.

Wire:

Galvanised mild steel electro-galvanised wire rope, 1960 N/mm² grade, 7×7 IWRC construction, manufactured to BS EN 12385.

The Toggles:

Austempered mild steel, BZP finished.

Toggle Dimensions	Length	
	Width	
Length (mm)	40.0 mm	
Width (mm)	5.0 mm	
Gauge (mm)	1.08 mm	
Slot length (mm)	20.0 mm	
Slot width (mm)	1.53 mm	
Maximum hole diameter for install	12 mm	